

The VT CORP Electronic Packer Model "VTC-GFPN" is a gravity feed packer specifically for granular products. The GFPN is a stationary open-mouth bag filling machine that weighs bulk material from 20 to 50 kg at the same time.

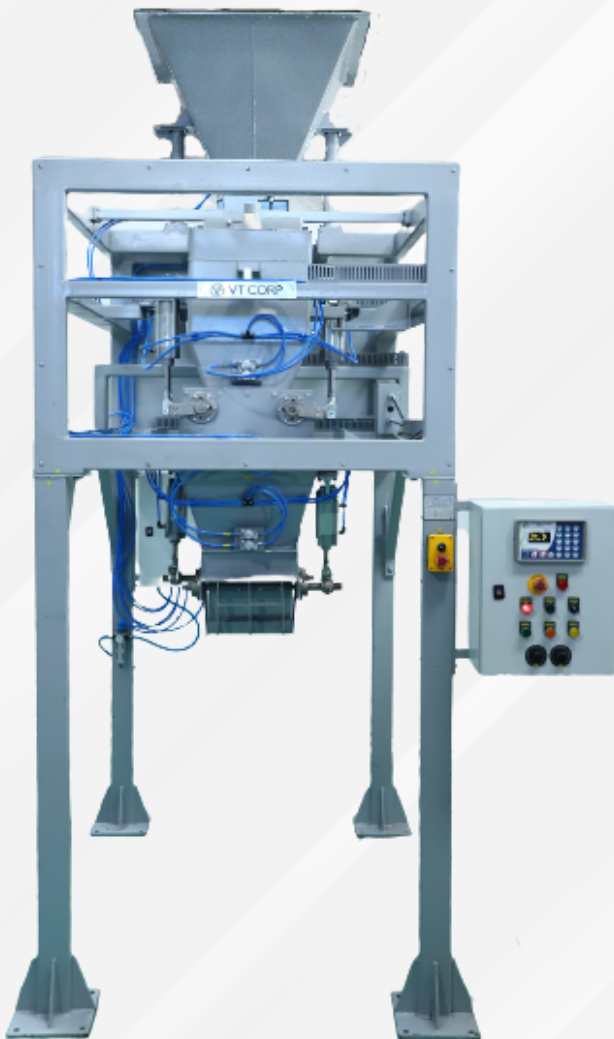

600 bags/hr*

Feed Rate

20 to 50 Kg

Packing Range

±20 to ±30 gm

Accuracy in 50 Kg Bag

Open Mouth type

Bag Type

Key Features :

- Microprocessor-based stationary packer
- Digital weighing system with indicator
- Latest technology and user-friendly designs
- Three stages of filling of the material inside the bag ensure better accuracy in weighments
- The same machine can be used for packing materials in jute, HDPE (woven), or paper bags (non-laminated)
- Easy availability of spares and after-sales service

Machine Specifications

Model	GFPN 1.1	GFPN 1.2
Weighing buckets	1	2
Discharge	1	2
Feed Rate (Bags/hour)	400	600
Filling Speed (Tons/Hour)	20 Ton	60 Ton
Bag Type	Open mouth	
Bag Material	HDPE, Jute	
Filled Weight (Kg)	05~50	
Accuracy in 50Kg Bag	±20 to ±30 gm	
Material Can Be Packed	Sugar, Rice, Food Grains, & Chemicals, Plastic Granules, Fertiliser ,etc.	
Bulk Density of Material (Tons/m 3)	0.8 to 1.4	
Power Supply	380 / 440 VAC 3φ @50Hz	
Air consumption	7 CFM @100 PSI	
After Sales Service & Spare Part Availability	Yes	

Type of Bags :



Open Mouth Bags

Bag Clamp Unit :

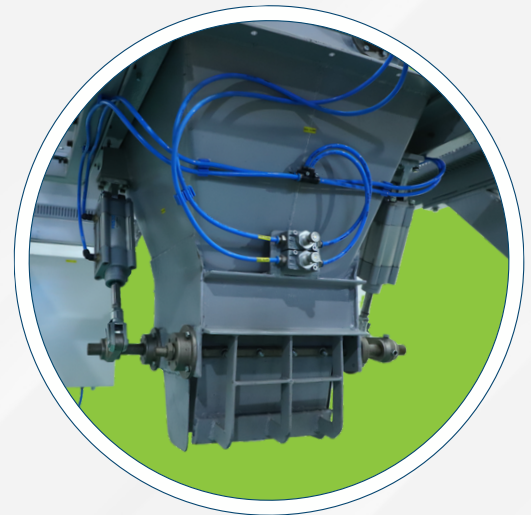

Isometric View :

GFPN 1.2 - Double weighing single discharge

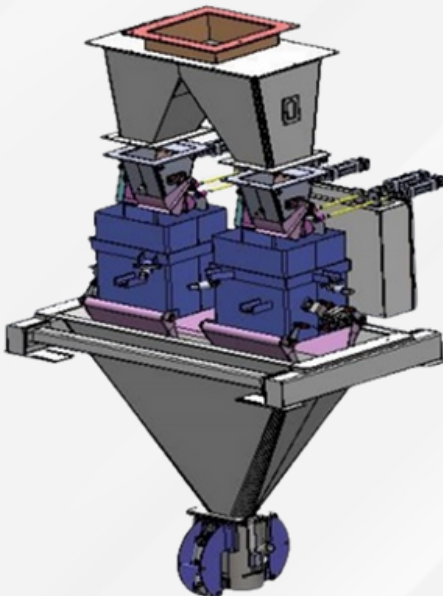

Application :

- Sugar, Rice, Food Grains, Chemicals, Plastic Granules, Fertilizer, etc.

VT CORP PVT LTD

Address: 901, Windfall, Sahar Plaza, J B Nagar, Andheri (East), Mumbai – 400059, India
 Tel: +91 22 6108 1200 | Mob: +91 9323125586 | Email: sales@vtcorp.in | www.vtcorpindia.com

ISO 9001-2015 CERTIFIED COMPANY

@vtcorpindia    